



PARKERETTE PACKAGED STEAM BOILER

Vertical Drum Spiral Water Tube

1 1/2 to 3 H.P. Gas Fired

THE PARKER DESIGN

The Parker water tube design offers an extremely efficient, reliable steam boiler built for the long term and ease of maintainance. The Parker design offers many advantages. Compare ours to the competition.



Parkerette Packaged Steam Boiler

1 1/2 to 3 H.P.



ADVANTAGES

1. Safety

The Parker tube bundle is extremely flexible and offers a long life with a 20 year warranty against thermal shock. No Parker Boiler has ever been known to experience an internal explosion.

2. Large Heating Surface

A large amount of heating surface provides increased efficiency and minimizes chances of scaling. Compare ours to the competition.

3. Simplicity

The Atmospheric Burner System, control system and the entire boiler are furnished so that it is simple to operate by regular personnel. Simplicity is a decided advantage as there are no expensive blowers, complicated controls, or burner adjustments, as is necessary on many boilers.

4. All Welded Tube Bundle

Parker tubes are 1" O.D. Grade SA-53 spiral tubes, welded in headers with no internal fittings exposed to the

heat area. Tubes are furnished in complete sets that are easy and inexpensive to replace. All tubes are flexibly arranged to permit free expansion and contraction to eliminate the warping or leaking, typical of rigid construction.

5. Codes

All Parker Steam Boilers are manufactured in accordance with the ASME Power & Heating Boiler Codes and registered with the National Board of Boiler and Pressure Vessel Inspectors.

The standard natural gas fired model is furnished as an Underwriters' Laboratories, Inc. Listed Gas Fired Boiler Assembly and displays their symbol on the nameplate. Outdoor, propane and Low NOx models are ETL listed. Canadian models are C-ETL Listed Industrial and Commercial Gas Fired Packaged Boilers certified to CAN/CGA 1-3.1 and UL 795.

PARKER BOILER CO.

5930 Bandini Boulevard
Los Angeles CA 90040
Fax (323) 722-2848
www.parkerboiler.com
Phone (323) 727-9800

PARKERETTE PACKAGED STEAM BOILER

Vertical Drum Spiral Water Tube

1 1/2 to 3 H.P. Gas Fired

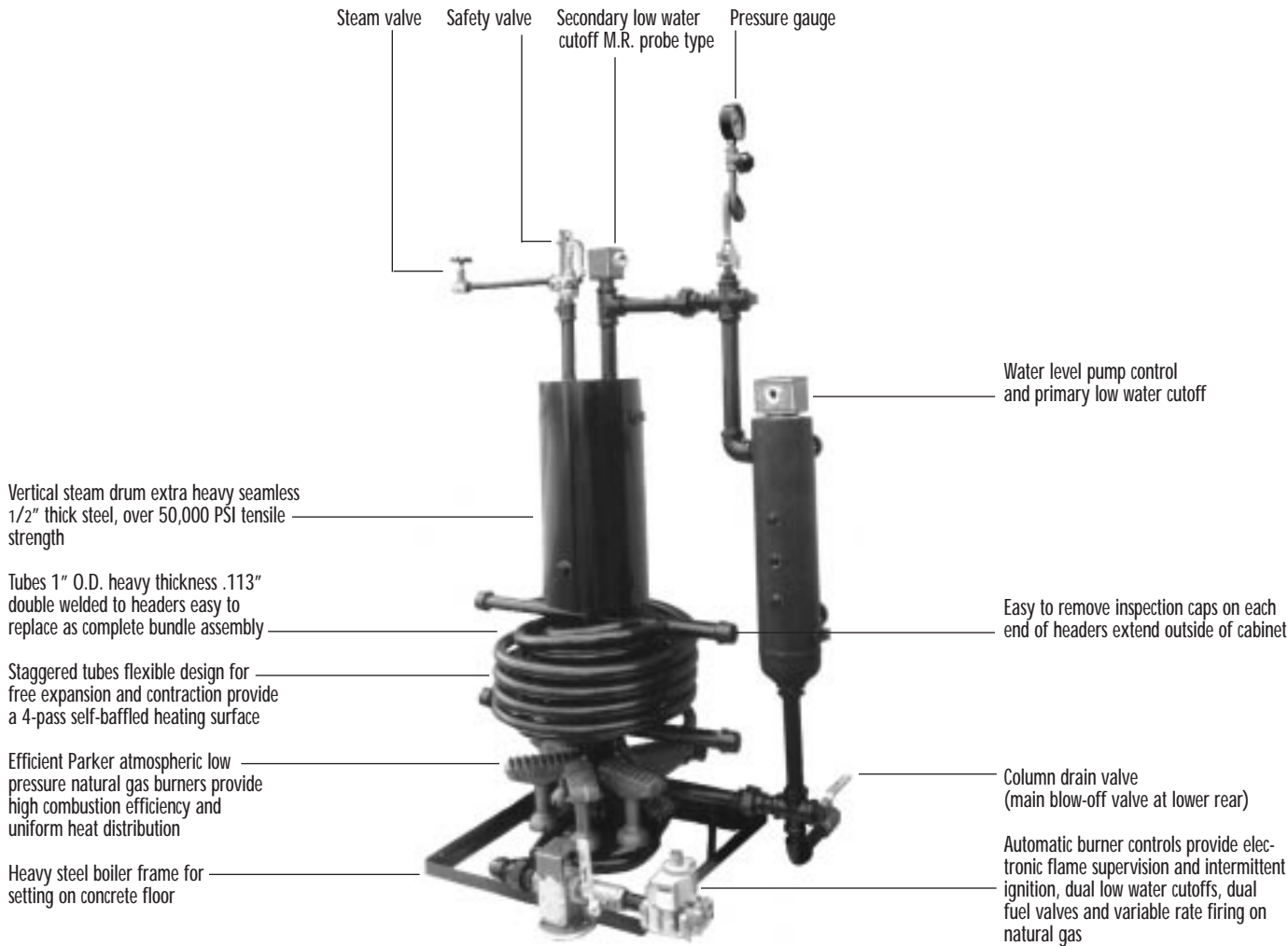

Vertical steam drum extra heavy seamless 1/2" thick steel, over 50,000 PSI tensile strength

Tubes 1" O.D. heavy thickness .113" double welded to headers easy to replace as complete bundle assembly

Staggered tubes flexible design for free expansion and contraction provide a 4-pass self-baffled heating surface

Efficient Parker atmospheric low pressure natural gas burners provide high combustion efficiency and uniform heat distribution

Heavy steel boiler frame for setting on concrete floor

Water level pump control and primary low water cutoff

Easy to remove inspection caps on each end of headers extend outside of cabinet

Column drain valve (main blow-off valve at lower rear)

Automatic burner controls provide electronic flame supervision and intermittent ignition, dual low water cutoffs, dual fuel valves and variable rate firing on natural gas

THE PARKER DESIGN

A time proven product backed by one of the largest and most successful manufactures of packaged steam boilers whose name is synonymous with quality and safety. Every boiler is thoroughly factory fire tested and is required to meet the highest standards in all phases of mechanical and operating efficiency before shipment.

6. Low Cost Operation

The staggered tubing design provides a 4-pass self-baffled heating surface with uniform heat distribution to permit maximum heat transfer resulting in lower stack temperatures and more economical operation.

7. Ease of Inspection and Repair

Any boiler may eventually require retubing depending on care and operating conditions. Retubing does not require special tools, skills or welding as is necessary on most boilers designed with rolled tubes.

8. Fast Heat-Up

Our boiler requires less than ten minutes to heat up to 100 PSI from a cold start which is a considerable time and fuel saver.

9. Heavy Insulated Cabinet

The cabinet is durably constructed with two thicknesses of heavy steel, insulated on all sides with high temperature thermal fiber insulation to effectively reduce heat losses to a minimum.

5930 Bandini Boulevard
 Los Angeles CA 90040
 Fax (323) 722-2848
 www.parkerboiler.com
 Phone (323) 727-9800

