

PARKER INDUSTRIAL HORIZONTAL DRUM STEAM BOILER
7 TO 25 H.P. – ATMOSPHERIC GAS FIRED - OUTDOOR MODEL

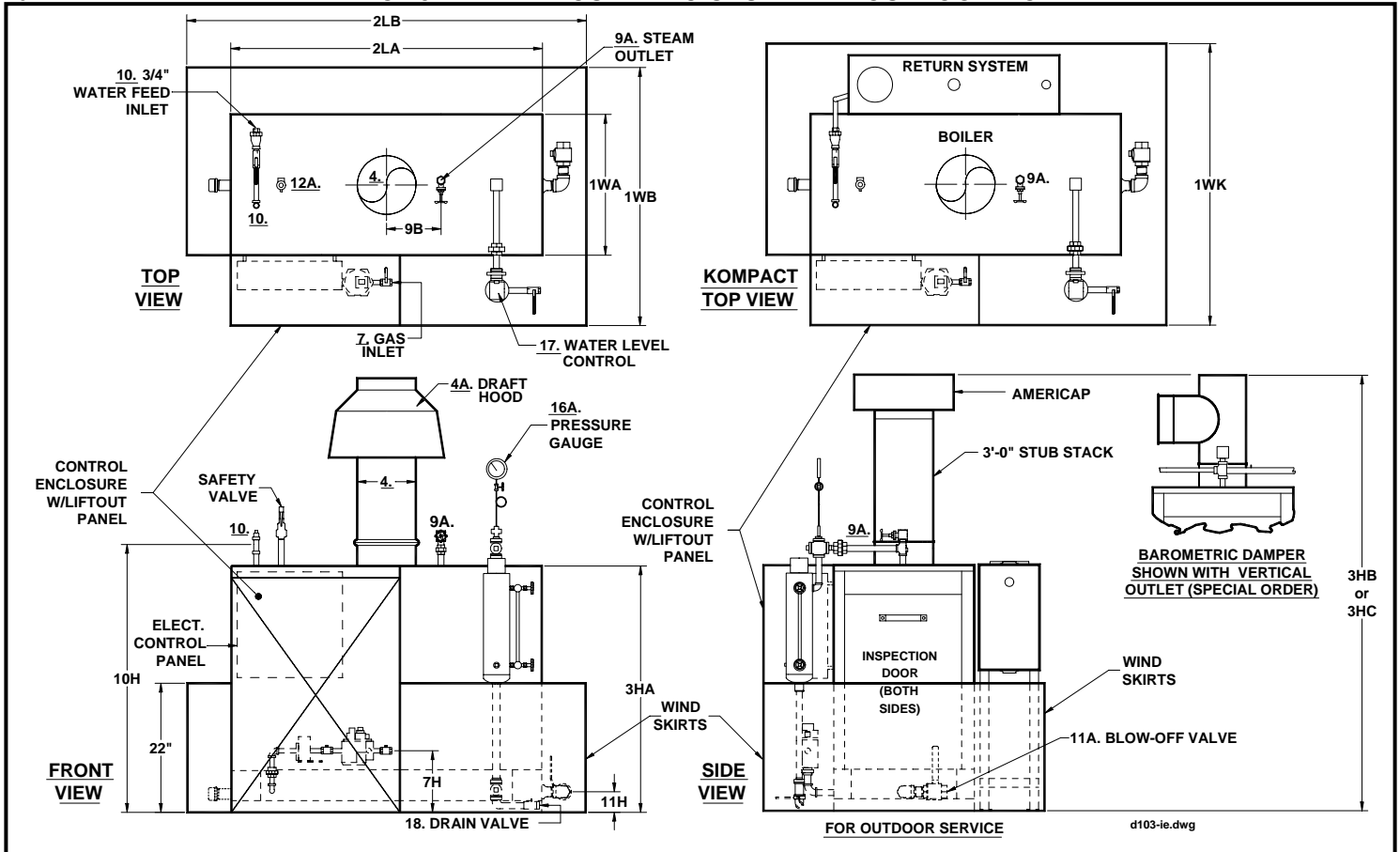

		MODEL NO.	103-7	103-9.5	103-15	103-20	103-25
NO.		HORSEPOWER	7 HP	9.5 HP*	15 HP	20 HP	25 HP**
A	BTU Input	1000's BTU/HR.	301	398	645	860	1075
B	BTU Output at rating from and at 212°F	1000's BTU/HR.	241	318	516	688	860
C	Heating Surface	SQ. FT.	47	68	82.5	106	132
D	Rated Steaming Capacity from and at 212°F	LBS./HR.	242	328	518	690	863
1WA	Width Cabinet Only	IN.	21	24	27	30	36
1WB	Width Overall Including Wind Skirts	IN.	41	44	47	50	56
1WK	Width Parker Compact - (Boiler With Return System) Including Wind Skirts	IN.	45	48	51	57	63
2LA	Length of Cabinet Only	IN.	42	53	53	61	62
2LB	Length Overall Including Wind Skirts	IN.	57	68	69	76	78
3HA	Height of Cabinet Only	IN.	42	42	42	46	46
3HB	Height Overall Including Draft Hood - (Std.)/ 3'0" Stub Stack & Americap (approx.)	IN.	72/89	74/91	76/93	82/100	82/100
3HC	Height Overall Including Barometric Damper (Vert. Outlet/Horizont. Outlet)-(Spec. Order)	IN.	58/55	61/59	64/61	68/65	72/68
4A	Vent Stack Diameter with Draft Hood - (Standard)	IN.	8	10	12	14	14
4B	Vent Stack Diameter with Barometric Damper - (Special Order)	IN.	6	8	10	10	12
7A	Gas Inlet Size - Standard Nat. Gas/ Supply Press. Min: 7" WC; Max: 14" WC	IN.	3/4	3/4	1	1-1/2	1-1/2
7A1	Natural Gas Manifold Pressure at Burner	IN. WC	4	4	4	4	4
7B	Gas Inlet Size - High Press. Nat. Gas & Propane Gas / Supply Press. 1-5 PSI	IN.	3/4	3/4	3/4	1-1/2	1-1/2
7B1	Propane Gas Manifold Pressure at Burner	IN. WC	18	18	18	18	18
7H	Gas Inlet Height From Floor	IN.	11	11	12	13	13
9A HP	Steam Valve Size - High Pressure 60 to 250 PSI	IN.	3/4	1	1	1	1-1/4
9 LP	Steam Outlet Size - Low Pressure 15 PSI or less - (Special Order)	IN.	1-1/2	2	2	2	2-1/2
9B	Steam Outlet Location - From Center of Boiler	IN.	7	9	9	12	12
10H	Water Inlet Height From Floor	IN.	45	45	45	50	50
11A	Blow-off Valve Size	IN.	1	1	1	1-1/4	1-1/4
11H	Blowdown Line Height From Floor	IN.	3	3	3	3	3
12A HP	Safety Valve Drain Size - High Pressure - 100 PSI - Standard	OUTLET IN.	1	1	1	1-1/4	1-1/4
12A LP	Safety Valve Drain Size - Low Pressure - 15 PSI ("H" Code)- (Special Order)	OUTLET IN.	3/4	1-1/2	1-1/2	1-1/2	2
18	Water Column Drain Valve Size	IN.	3/4	3/4	3/4	1	1
J	Net Weight Of Boiler	LBS.	910	1205	1400	1820	2095
K	Domestic Crated Shipping Weight of Boiler	LBS.	1055	1360	1555	2000	2325
L	Same with Return System or Kompact Mounting	LBS.	1350	1650	1850	2360	2865
MINIMUM LISTED CLEARANCES TO COMBUSTIBLE CONSTRUCTION:		12"	48"	6"	12"		
		Cabinet Sides & Rear	Cabinet Top	Draft Hood Vent Connector	Baro. Damper Chimney Connector		
Recommended Clearances for Access: Inspection Doors 18"; Controls 24"; Electrical Panel 30"; Additional Space may be required by Local Codes							

*10 H.P. available with same dimensions as 9.5 H.P. except: 430MBTU/Input; 344MBTU/Output, 340 Lbs./Hr., 1" Low Pressure Nat. Gas Inlet Size

**23 H.P. available with same dimensions as 25 H.P. except: 995MBTU/Input; 796MBTU/Output; 793 Lbs./Hr.

Notes: All of the above dimensions are for a standard trim model. Due to continuous improvement, specifications are subject to change without notice.